

LaserSpeed

Non-Contact Speed & Length
Gauge for the Metals Industry



BETA LaserMike

Non-Contact Speed & Length Measurement

Precision speed and length measurements are critical for controlling production costs and improving process control for the steel and nonferrous metals industries. Traditional contact rollers and tachometers have inherent problems with slippage and mechanical wear. Both of these problems cause increased scrap, increased maintenance costs and reduce the quality of the end product. LaserSpeed® non-contact speed and length gauges solve all of the problems of mechanical contact rollers and tachometers.

LaserSpeed gauges can measure the speed and length of any product using an optical, non-contact technology called Dual Beam Laser Doppler Velocimetry. LaserSpeed gauge were first introduced into the metals industry in 1984 and have been growing in usage ever since. There are thousands of LaserSpeed gauges installed world wide.

A breakthrough in electro-optics design enables Beta LaserMike's LaserSpeed gauges to produce highly accurate, non-contact speed

and length measurements at a surprisingly low cost. To accomplish this, the LaserSpeed gauge uses the Laser Doppler Velocimeter technology coupled with autocorrelation, the most advanced, digital signal processing algorithm, and new single-chip integrated circuit technology.

LaserSpeed gauges have no moving parts, use 100% solid-state digital technology, and are permanently calibrated—resulting in significant time and money savings. With accuracy better than $\pm 0.05\%$, the LaserSpeed gauge is the ideal gauge for replacing contact tachometers which are prone to measurement errors caused by slippage, dirt build-up, and day-to-day wear problems.

The LaserSpeed gauge is a complete system integrated into a compact package. The processor is incorporated inside the gauge, making it easy to maintain, troubleshoot and operate—resulting in a lower cost of ownership. There are two series of LaserSpeed gauges: the LS8000 series and the LS9000 series.

Smart, compact design provides **High Accuracy** at an affordable price

► LS8000 Series

The LS8000 series of gauges measures the absolute value of speed and length using Dual Beam Laser Doppler Velocimetry, eliminating slippage and wear problems of contact rollers and tachometers. A wide range of standoff distances are available, ranging from 300 mm to over 2500 mm (12 in. to 98.4 in.) and have the ability to measure speeds up to 20000 m/min (65,000 ft/min.)

► LS9000 Series

(Zero Speed and direction detection)

The LS9000 series of gauges is based on the LS8000 technology with the added feature of being able to measure zero speed and automatically detect forward and reverse direction. This is accomplished by using a proprietary optics system coupled with special electronics that allows the LS9000 to accurately measure speed and length, including zero speed, and automatically determine the direction the product is traveling, while maintaining the same high accuracy as the LS8000.

The LS9000 gauge is well suited for applications where the product moves very slowly, like continuous casters, for positioning control where the product stops and backs up and for applications where the product reverses direction.

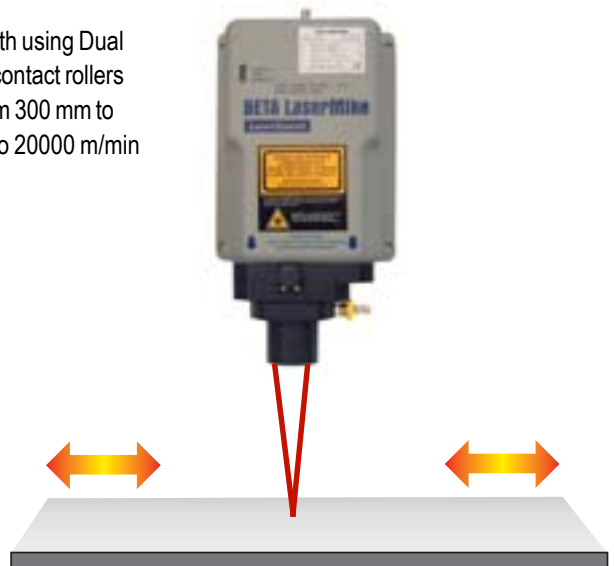

BETA LaserMike

Laser Doppler Velocimetry Principle

LaserSpeed uses dual-beam laser interferometer technology to measure product velocity (speed), which is integrated over time to measure length.

Fringe distance is a function of laser wavelength and beam angle:

$$d = \frac{\lambda}{2 \sin \kappa}$$

Velocity is distance over time:

$$v = \frac{d}{t}$$

Period is the inverse of frequency:

$$t = \frac{1}{f}$$

Velocity is integrated to find length:

$$L = \int_0^T v dt$$

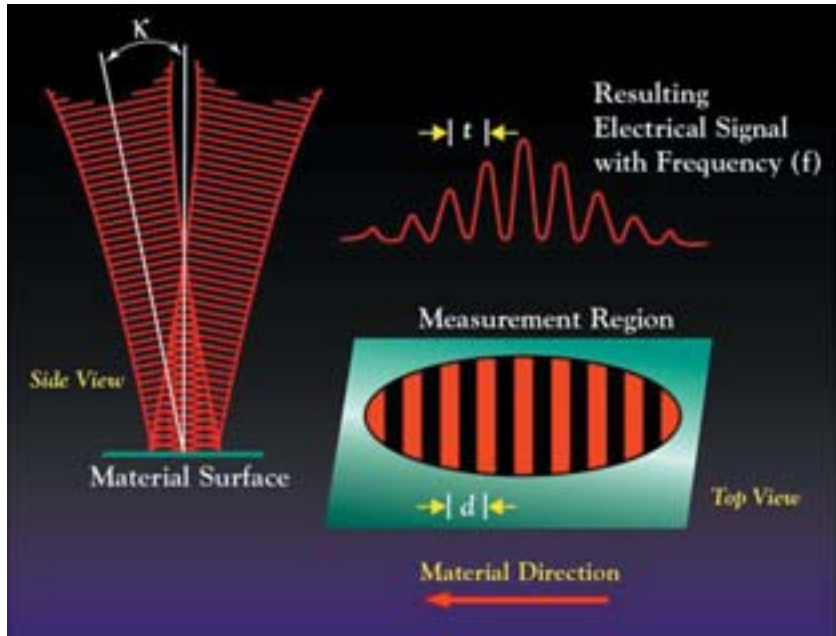

Highly accurate

Length & Speed

measurements at any location

Since 1984...

LaserSpeed® gauges have been improving mill productivity, saving money and improving product quality with applications as varied as:

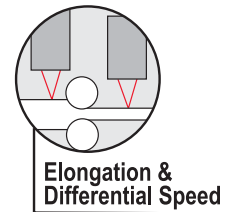
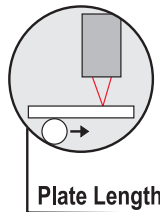
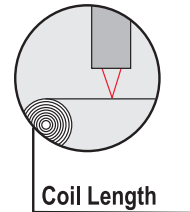
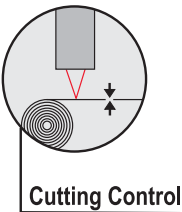
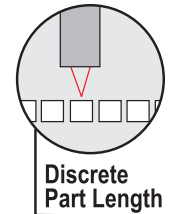
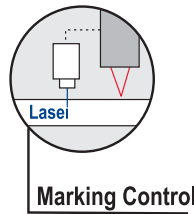
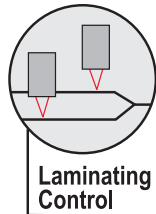
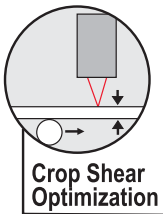

LaserSpeed®



Elongation—
Wet Temper Mill



MFAGC—
Cold Rolling Mill



Cutting Control—
Tube Mill



Continuous Caster

LS8000/LS9000

5

LS8000E/LS9000E

6

LS8000X/LS9000X

7

LS8000 Specifications

8

LS9000 Specifications

9

LS8000-C/LS9000-C

10

**LS8000-C/LS9000-C
Specifications**

11

Accessories

12

Designed for steel and non-ferrous metal manufacturing

The LaserSpeed gauge is the base sensor for all of the models in the LaserSpeed series of gauges. With an accuracy better than +/-0.05%, it is the ideal replacement for contact tachometers which are prone to measurement errors caused by slippage, dirt build-up and day-to-day wear problems in the metal manufacturing industry. There are two gauge types, the LS8000 that measures the absolute value of the speed and length and the LS9000 that can measure zero speed and determine the direction the material is moving. Both gauges are well suited for a range of applications including, but not limited to:

- Steel Slabs
- Cold Steel Strip
- Steel Bar Length
- Plate Length
- Tube Length
- Bar Length
- Process Lines
- Painting Lines
- Galvanizing Lines



LS8000 Series LaserSpeed Gauge shown with Air Wipe

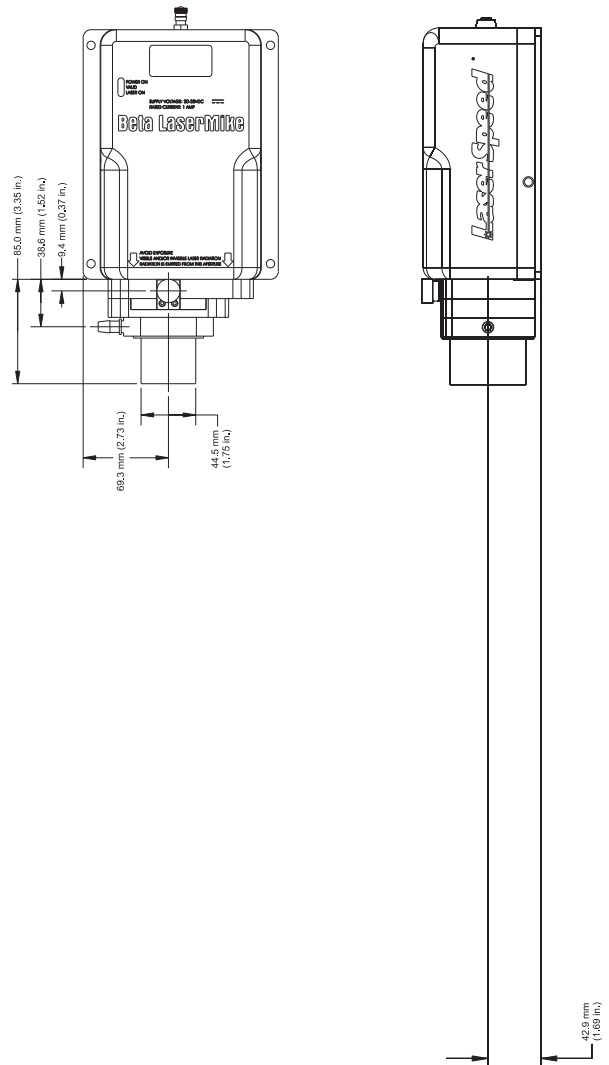

LaserSpeed®

Designed for the harsh environment of steel and non-ferrous metal manufacturing

The LaserSpeed 8000E/9000E gauge takes the base LS8000/9000 sensor and houses it within a rugged environmental housing for double-sealed protection against hot and hostile environments. The system works on all types of products including rod, bar, tube, pipe, slabs, cold strip, hot strip, plate and profile products. With various options and accessories, this gauge provides a complete solution for the harsh environment of steel and non-ferrous metal manufacturing, including:

- Temper/Skin Pass Mills
- Slabs
- Cold Steel Strip
- Bar Mills
- Profile Mills
- Tube Mills
- Plate Mills
- Foil Mills
- Slitter Lines
- Galvanizing Line
- Annealing Line
- Painting Line
- Processing Lines
- Wire Rod Mills



**LS8000E Series
LaserSpeed Gauge
shown with Air Wipe**



Exit of Cold Rolling Mill

LS8000E WITH AIR PURGE (SEE TABLE)

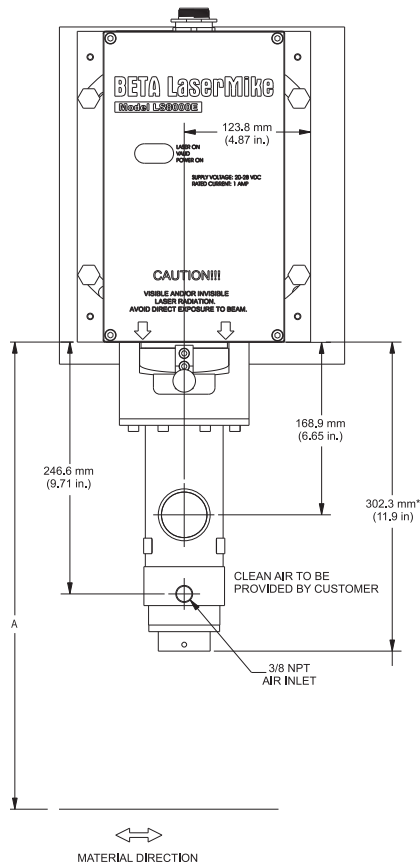

LS8000E WITH AIR WIPE (SEE TABLE)

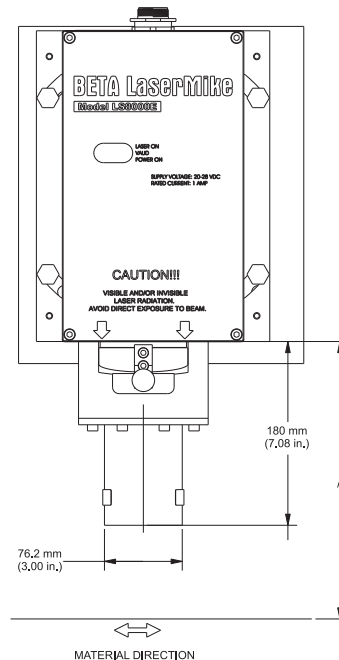

*Air Purge Model 982725 shown

Model	A
LS8000/9000-325E	2471.5 mm (97.3 in.)
LS8000/9000-320E	1971.5 mm (77.6 in.)
LS8000/9000-315E	1471.5 mm (57.9 in.)
LS8000/9000-310E	971.5 mm (38.25 in.)
LS8000/9000-306E	571.5 mm (22.5 in.)

Designed for the extreme environment of steel and non-ferrous metal manufacturing

The LaserSpeed 8000X/9000X gauge is designed for the toughest environments in metal manufacturing where heavy steam, mist and sprays occur. The LS8000X/9000X gauge has a stainless steel housing protecting the gauge—a built-in air purge keeps the quick-change window clean for lower maintenance needs. The LS8000X/9000X gauges are well suited for a range of applications including, but not limited to:

- Hot Rolling Steel Mills
- Interstand Cold Rolling Steel Mills
- Heavy Steam Applications
- Extreme Hot and Hostile Environments
- Continuous Caster
- Billet/Bloom Casters
- Thin Slab Caster

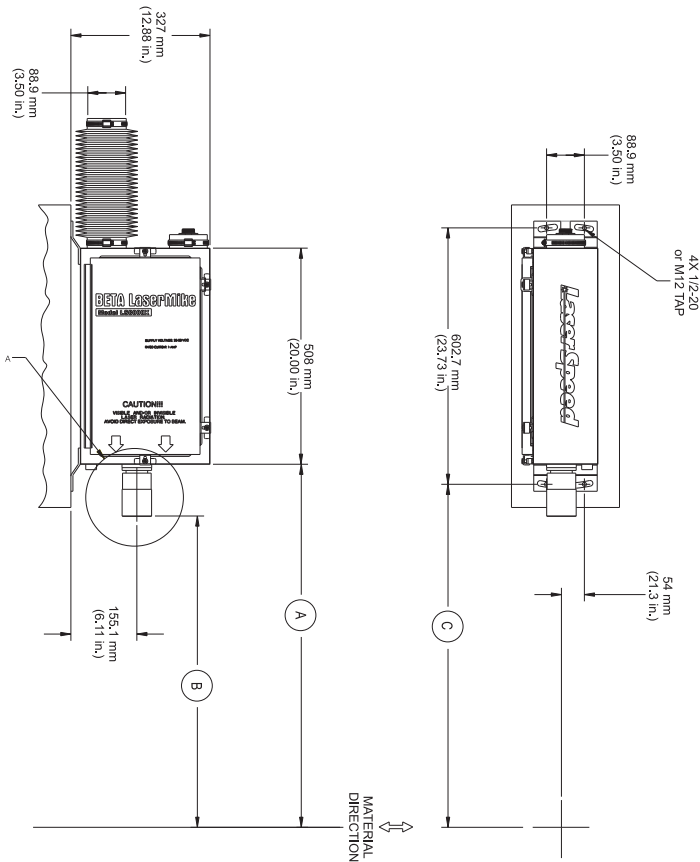

Model	A	B	C
LS8000/9000-325X	2353.4 mm	2231.8 mm	2306.3 mm
LS8000/9000-320X	1853.4 mm	1731.8 mm	1806.3 mm
LS8000/9000-315X	1353.4 mm	1231.8 mm	1306.3 mm
LS8000/9000-310X	835.4 mm	731.8 mm	806.3 mm
LS8000/9000-306X	453.4 mm	331.8 mm	406.3 mm

LaserSpeed®

LS8000 Specifications

Length/Speed Operation without Stopping, Reversing and/or Slow Speed Operation

LS8000	-303	-306	-310	-315	-320	-325
Standoff Distance	300 mm (12 in.)	600 mm (24 in.)	1000 mm (39.4 in.)	1500 mm (59.1 in.)	2000 mm (78.1 in.)	2500 mm (98.4 in.)
Speed Range	0.4-4000 m/min (1.3-13100 ft/min)	0.8-8000 m/min (2.6-26200 ft/min)	1.0-12000 m/min (3.2-39400 ft/min)	2.0-19000 m/min (6.5-62400 ft/min)	3.0-20,000 m/min (9.8-65,600 ft/min)	4.0-20,000 m/min (13-65,600 ft/min)
Measurement Depth of Field	35 mm (1.4 in.)	50 mm (2 in.)	100 mm (4.0 in.)	200 mm (8.0 in.)	200 mm (8.0 in.)	200 mm (8.0 in.)

LS8000-3 General Specifications

Accuracy

Depth of Field <75 mm	<+/-0.05 % of reading
Depth of Field >75 mm	<+/-0.1% of reading

Repeatability

+/-0.02%

Measurement Rate

>50,000/s

Acceleration Rate

>500 m/s²

Starting / Ending Length Correction

- Yes

Serial I/O

Data Available - RS-232 / RS-422
- Speed, Length
- Quality Factor, Status

Baud Rate

- 115K, 230K
- 19.2K, 38.4K, 57.6K

Ethernet -Optional

- 10/100, UDP,TCP
- Speed, Length
- Quality Factor, Status

Status via Serial I/O or Optional Ethernet

- Laser at Temperature
- Laser Interlock
- Shutter Position
- Valid Measurements
- Material Present
- System Ready

Quadrature Pulse

Output 1

- Opto isolated
- Scaleable pulse amplitude (5-24 V)
- Selectable pulses/unit
- 250 KHz max pulse rate

Output 2

- RS422 Drivers
- Selectable pulses/unit
- 5 MHz max pulse rate

Gauge Power

- 24VDC (+/-4 VDC) @ 1.5 Amp

Gauge Temperature

- 5 to 45°C (41 to 113°F)

Specifications are subject to change without notice.

LS8000

Gauge Size

-303, -306, -310	203 X 159 X 95.2 mm (8 X 6.3 X 3.75 in.)
-315, -320, -325	228.6 X 159 X 95.2 mm (9 X 6.3 X 3.75 in.)

Gauge Weight

-303, -306, -310	3.4 kg (7.5 lbs)
-315, -320, -325	3.7 kg (8.3 lbs)

Water Cooling

1.0 to 3.8 l/min,
Typical 1.5 l/min (0.4 gpm)

Relative Humidity

Non-condensing

Degree of Protection

IP67

LS8000E

Gauge Size

-306, -310	362 X 229 X 158 mm (14.25 X 9 X 6.25 in.)
-315, -320, -325	362 X 229 X 158 mm (14.25 X 9 X 6.25 in.)

Gauge Weight

-306, -310	18 kg (40 lbs)
-315, -320, -325	Varies depending on Air Wipe/Air Purge

Environment Temp

-10 to 150°C (14 to 302°F)

Water Cooling

1.0 to 3.8 l/min (0.26 – 1gpm)

Compressed Air

Instrument Grade
Air Wipe 50 l/min (1.8 cfm) Typical,
Air Purge 6.2 – 8.3 Bar, 1,200 l/min (90 -120 psi, 45 scfm)

Relative Humidity

Non-condensing

Degree of Protection

IP67

LS8000X

Gauge Size

-306, -310	508 X 327 X 186 mm (20 X 12.88 X 7.32 in.)
-315, -320, -325	508 X 327 X 186 mm (20 X 12.88 X 7.32 in.)

Gauge Weight

-306, -310	24.9 kg (55 lbs)
-315, -320, -325	24.9 kg (55 lbs)

Environment Temp

-10 to 200°C (14 to 392°F)

Water Cooling

1.0 to 3.8 l/min (0.26 – 1gpm)

Compressed Air

Instrument Grade
Air Wipe 50 l/min (1.8 cfm) Typical,
Air Purge 6.2 – 8.3 Bar, 1200 l/min (90 -120 psi, 45 scfm)

Relative Humidity

Non-condensing

Degree of Protection

IP67

Length/Speed with Stopping, Reversing and/or Slow Speed Operation

LS9000	-303	-306	-310	-315	-320	-325
Standoff Distance	300 mm (12 in.)	600 mm (24 in.)	1000 mm (39.4 in.)	1500 mm (59.1 in.)	2000 mm (78.1 in.)	2500 mm (98.4 in.)
Speed Range	0..+/-4000 m/min (0..+/-13100 ft/min)	0..+/-8000 m/min (0..+/-26200 ft/min)	0..+/-12000 m/min (0..+/-39400 ft/min)	0..+/-19000 m/min (0..+/-62400 ft/min)	0..+/-20000m/min (0..+/-65600ft/min)	0..+/-20000m/min (0..+/-65600ft/min)
Measurement Depth of Field	35 mm (1.4 in.)	50 mm (2.0 in.)	100 mm (4.0 in.)	200 mm (8.0 in.)	200 mm (8.0 in.)	200 mm (8.0 in.)

LS9000 General Specifications

Accuracy

Depth of Field <75 mm	<+/-0.05 % of reading
Depth of Field >75 mm	<+/-0.1% of reading

Repeatability

+/-0.02%

Measurement Rate

>100,000/s

Acceleration Rate

>500 m/s²

Starting / Ending Length Correction

- Yes

Serial I/O

Data Available	- RS-232 / RS-422 - Speed, Length - Quality Factor, Status
Baud Rate	- 115K, 230K - 19.2K, 38.4K, 57.6K

Ethernet -Optional

- 10/100, UDP,TCP
- Speed, Length
- Quality Factor, Status

Status via Serial I/O or Optional Ethernet

- Laser at Temperature
- Laser Interlock
- Shutter Position
- Valid Measurement
- Material Present
- System Ready

Quadrature Pulse

Output 1	- Opto isolated - Scaleable pulse amplitude (5-24 V) - Selectable pulses/unit - 250 KHz max pulse rate
Output 2	- RS422 Drivers - Selectable pulses/unit - 5 MHz max pulse rate

Gauge Power

- 24VDC (+/-4 VDC) @ 1.5 Amp

Gauge Temperature

- 5 to 45°C (41 to 113°F)

Specifications are subject to change without notice.

LS9000

Gauge Size

-303, -306, -310	203 X 159 X 95.2 mm (8 X 6.3 X 3.75 in.)
-315, -320, -325	228.6 X 159 X 95.2 mm (9 X 6.3 X 3.75 in.)

Gauge Weight

-303, -306, -310	3.4 kg (7.5 lbs)
-315, -320, -325	3.7 kg (8.3 lbs)

Water Cooling

1.0 to 3.8 l/min,
Typical 1.5 l/min (0,4 gpm)

Relative Humidity

Non-condensing

Degree of Protection

IP67

LS9000E

Gauge Size

-306, -310	362 X 229 X 158 mm (14.25 X 9 X 6.25 in.)
-315, -320, -325	362 X 229 X 158 mm (14.25 X 9 X 6.25 in.)

Gauge Weight

-306, -310	18 kg (40 lbs)
-315, -320, -325	Varies depending on Air Wipe/Air Purge

Environment Temp

-10 to 150°C (14 to 302°F)

Water Cooling

1.0 to 3.8 l/min (0.26 – 1gpm)

Compressed Air

Instrument Grade
Air Wipe 50 l/min (1.8 cfm) Typical,
Air Purge 6.2 – 8.3 Bar, 1.200 l/min
(90 - 120 psi, 45 scfm)

Relative Humidity

Non-condensing

Degree of Protection

IP67

LS9000X

Gauge Size

-306, -310	508 X 327 X 186 mm (20 X 12.88 X 7.32 in.)
-315, -320, -325	508 X 327 X 186 mm (20 X 12.88 X 7.32 in.)

Gauge Weight

-306, -310	24.9 kg (55 lbs)
-315, -320, -325	24.9 kg (55 lbs)

Environment Temp

-10 to 200°C (14 to 392°F)

Water Cooling

1,0 to 3,8 l/min (0.26 – 1gpm)

Compressed Air

Instrument Grade
Air Wipe 50 l/min (1.8 cfm) Typical,
Air Purge 6.2 – 8.3 Bar, 1200 l/min
(90 - 120 psi, 45 scfm)

Relative Humidity

Non-condensing

Degree of Protection

IP67

Designed for steel and non-ferrous metal manufacturing. Provides high accuracy at a revolutionary price.

A breakthrough in electro-optics design enables Beta LaserMike's LaserSpeed[®] series gauges to produce highly accurate, non-contact speed and length measurements at a surprisingly low cost. To accomplish this, the LaserSpeed gauges use autocorrelation, the most advanced digital signal processing algorithm, coupled with new single-chip integrated circuit technology.

The LS8000-C/LS9000-C series gauge is an industrial sensor that can be mounted inside the C-Frame of an x-ray gauge. The gauge can connect directly to a PLC or control computer. The LS8000-C/LS9000-C consists of a gauge, a mounting rail, a right angle mirror assembly and a safety cover. The mounting rail is designed so the gauge can be positioned at a specified distance. This feature allows complete flexibility in optimizing the standoff distance for each application.

The LS8000-C/LS9000-C gauge is well suited for applications where thickness and speed or length are required in the same location. This includes:

- Interstand Cold Rolling Mills
- Foil Mills
- Pipe and Tube Mills

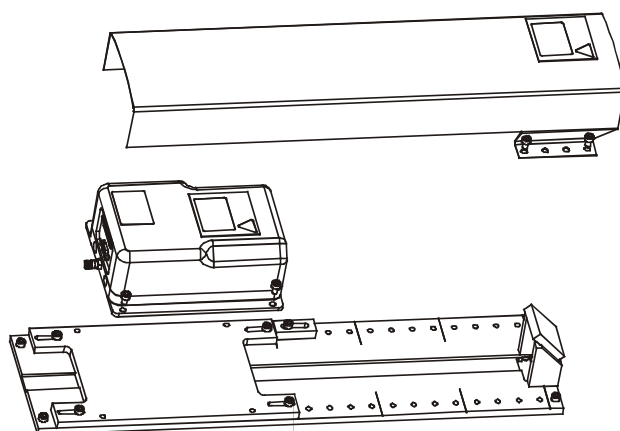

LS8000-C/LS9000-C	-306	-310
Standoff Distance	195 -510 mm (7.68- 20.08 in.)	595-910 mm (23.43-35.83 in.)
Speed Range	0.8 to 8000 m/min (2.6 to 26200 ft/min)	1.0 to 12000 m/min (3.2 to 39400 ft/min)
Measurement Depth of Field	50 mm (2 in.)	100 mm (4.0 in.)

LS8000-3/LS9000-3	
Accuracy	<+/-0.05% of reading
Repeatability	+/-0.02%
Measurement Rate	>50000/s
Acceleration Rate	>500 m/s ²
Starting / Ending Length Correction	- No
Serial I/O	- RS-232
Data Available	- Speed, Length - Quality Factor, Status
Baud Rate	- 115K, 230K - 19,2K, 38,4K, 57,6K
Status via Serial I/O	- Sensor at Temperature - Laser On - Shutter Open - Valid Measurements
Ethernet -Optional	- 10/100, UDP, TCP - Speed, Length - Quality Factor, Status
Quadrature Pulse Output 1	- Opto isolated - Scaleable pulse amplitude (5-24 V) - Fixed at 1000 pulses/unit - 250 kHz max pulse rate
Output 2	- Scaleable pulse amplitude (5-24 V) - Selectable pulses/unit - 250 KHz max pulse rate
Index Pulse Output	- Yes
Gauge Power	- 24VDC (+/-4 VDC) @ 1 Amp

Specifications are subject to change without notice.

Common Specifications

All LS8000/LS9000 Gauges	
User Isolated Voltage	5 to 24 VDC (300 mA)
Temperature Range	5 to 45°C (41 to 113°F)
Relative Humidity	Non-condensing
Water Cooling	1.0 to 3.8 l/min, Typical 1.5 l/min (0.4 gpm)
Degree of Protection	IP67
Output Rate	1 to 2047 ms in 1 ms increments
Units of Measure	Selectable
Speed	m/min, m/s, ft/min, ft/s, in/min, mm/min, yards/min, yards/sec
Length	m, ft, mm, in, yards

Optional Accessories

(for all LS8000-C/LS9000-C gauges)

- **Analog Converter:** Converts 0 to 2VDC speed output to; 0 to 10VDC, 0 to 5VDC, +/- 10VDC, +/-5VDC, 0 to 20 mA, 4 to 20 mA
- **Sensor Cable:** 3m, 10m, 20m, 30m, 50m lengths
- **Terminal Block:** Breakout box for sensor cable



Accessories

Gauge	E Housing	X Housing	Item	Description
✓	✓	✓	I/O Module	The I/O module takes the speed, length and status information from the gauge and provides various outputs for simple interfacing to a PLC. Outputs include a parallel I/O format, as well as Profibus or Ethernet fieldbus interfaces. The indicators on the front of the module allow the operator to check the status of the gauge with a quick glance. The module also provides power to the LaserSpeed and a keyswitch to control laser power. The light stack output can control a 24VDC Red/Yellow/Green light stack.
✓	✓	✓ ¹	Air Wipe/Quick Change Window	Designed for dirtier environments, the airwipe and quick change window help to ensure minimal downtime for cleaning.
	✓	✓ ¹	Beam Path Air Purge	In environments with heavy dust or steam, the laser beam path may need to be cleared for proper measurement. The beam path air purge efficiently accomplishes this with a 20:1 air amplification ratio.
	✓		Right-Angle Mirror Assembly	In some locations, perpendicular mounting of the gauge is not possible. The right-angle mirror assembly provides a mechanism to steer the laser at a 90° angle.
✓			C-Frame Enclosure	Designed to be mounted inside the C-Frame of an x-ray gauge, this enclosure consists of a mounting rail, a right angle mirror assembly, and a safety cover. The mounting rail is designed so the gauge can be positioned at a specified distance for complete flexibility in optimizing the standoff distance for each application.
	✓	✓	Air Services Cabinet	Mill-supplied compressed air is typically laden with dirt and oil, which can adversely affect system performance and increase maintenance requirements. The air services cabinet serves as a filtering and pressure regulating system to supply conditioned air necessary to keep the sensor windows free of these substances. The cabinet can also supply air to the optional beam path air purge.
	✓	✓	Water Chiller	When cooling water temperature is outside the 5-40° C range, it is necessary to use a Recirculating Water Chiller/Heater to improve measurement accuracy by stabilizing the optical components. Use of a Recirculating Water Chiller/Heater can also prevent water condensation from forming on the sensor by regulating the sensor temperature above the dew point.
✓	✓	✓	Power Line Conditioner	Available in 50Hz or 60Hz versions, the power line conditioner continuously provides clean power (free of power surges and voltage spikes) to the gauge.
	✓	✓	Break away cable	Low temperature cable connects between the E or X housing and the main cable. Has circular sealed connectors on both ends. Max temperature 90°C. Available in 10 meter length only.
	✓	✓	Break away cable	Hi temperature cable connects between the E or X housing and the main cable. Has circular sealed connectors on both ends. Max temperature 250°C. Available in 10 meter length only.
✓			Sensor Cable	Cable connects the gauge to breakout box or LaserSpeed I/O module. 25 Pin "D" connector on both ends.
	✓	✓	Sealed Sensor Cable	Cable with submarine circular connector for water tight connection to E and X housing. Connects to breakout box or LaserSpeed I/O module with 37 pin "D" connector. Jacket rated for kerosene and mill coolant. Max temperature 90°C.
✓	✓	✓	Analog Converter	Converter module converts the supplied 0 to 2VDC speed output to 0 to 10VDC, 0 to 5VDC, +/- 10VDC, +/-5VDC, 0 to 20 mA, or 4 to 20 mA.

¹Comes Standard with LS8000X/LS9000X

This unit is a class 3B laser product and Complies with EN60825-1:2001. Complies with 21 CFR 1040.10 and 1040.11 except for deviations pursuant to Laser Notice No. 50, dated July 26, 2001.



The following safety features required to comply with the Bureau of Radiological Health Class III laser requirements are included:

- Key-operated power switch on optional controller
- Laser indicator light on supply and laser
- Delayed laser startup-laser indicator light on prior to laser radiation
- Laser beam blocking device
- Interlock capability for remote shut-off

BETA LaserMike

Beta LaserMike USA

8001 Technology Blvd.
Dayton, OH 45424 USA
Ph: +1 937 233 9935
Fax: +1 937 233 7284

Beta LaserMike Europe

Unit 3, First Avenue
Globe Park, Marlow
Buckinghamshire, SL7 1YA
United Kingdom
Ph: +44 1628 401510
Fax: +44 1628 401511

Beta LaserMike Asia

SHANGHAI
BLOCK AUTOMATION.,LTD
Shanghai 200270, China
Ph: +86 21 66119899
Fax: +86 21 66119895

Visit our website at : www.betalasermike.com